 APPROVED PRODUCT CF5294	BS EN1154:1997+ A1:2002		3 8 4 1 1 4	
	CE	2812 CPR-AD5194	15	
UK CA	1121-CPR UK-AD7829		21	

## Regular Fixing

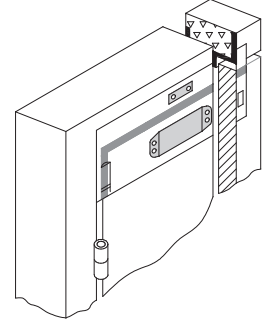

**1** Using the templates provided, mark and drill pilot holes into the door and frame.

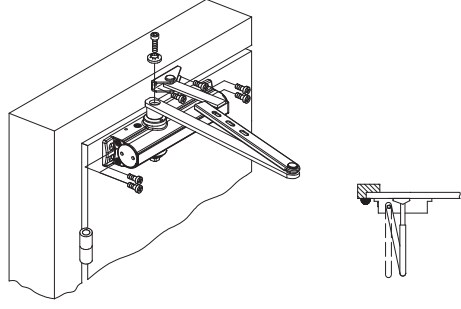

**2** Using the templates provided, fix the mechanism to the door as well as the armset and any necessary brackets.

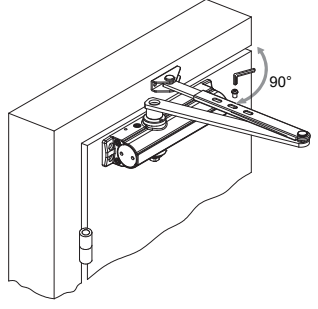

**3** Attach the armset to the mechanism ensuring the pre-loading requirement has been completed.

## Transom Fixing

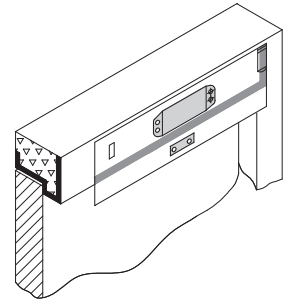

**1** Using the templates provided, mark and drill pilot holes into the door and frame.

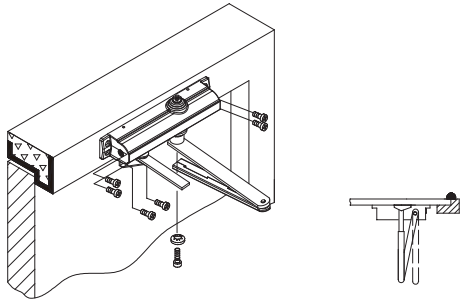

**2** Using the templates provided, fix the mechanism to the door as well as the armset and any necessary brackets.

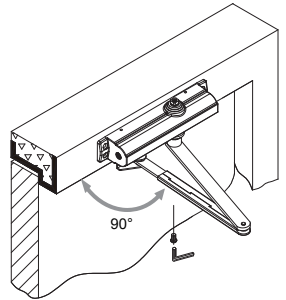

**3** Attach the armset to the mechanism ensuring the pre-loading requirement has been completed.

## Installation Instructions: Please refer to actual size template for exact fitting dimensions

### Pre-Loading of Arm

For the unit to provide the optimum performance and overcome any resistance upon closing it is recommended that the armset is "pre-loaded". To pre-load, reposition the fixing angle of the arm onto the mechanism so that the end of the closing cycle would be past the stop position, as indicated below.

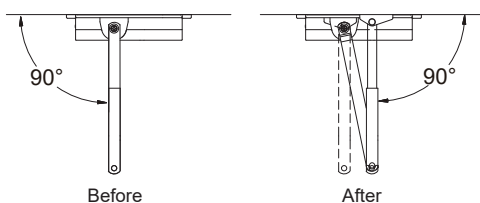

### Adjustment Details

This unit is a power adjustable mechanism. Power / force adjustment is carried out by a single adjustment valve in the end of the mechanism. The unit is pre-set in the factory at EN size 3. Please see table below for adjustment details for each power size. Instructions for adjusting this product are detailed overleaf.

### Fixing in Fig.1 / Fig.61

Power size	Max. Door width	Max. Door weight	Max. Door opening	Number of turns
No.1	750mm	20Kg	180°	7CCW
2	850mm	40Kg	180°	4CCW
* 3	950mm	60Kg	180°	0
4	1100mm	80Kg	165°	4CW

\* Factory preset  
CW:Clockwise CCW:Counterclockwise

 APPROVED PRODUCT CF5294	BS EN1154:1997+ A1:2002		3 8 4 1 1 4	
	CE	2812 CPR-AD5194	15	
UK CA	1121-CPR UK-AD7829		21	

## Parallel Fixing

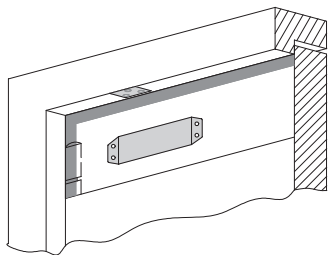

**1** Using the templates provided, mark and drill pilot holes into the door and frame.

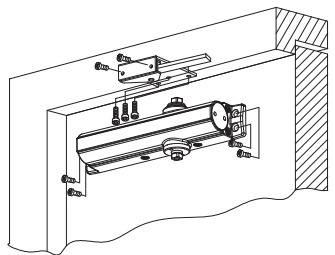

**2** Using the templates provided, fix the mechanism to the door as well as the armset and the parallel arm bracket.

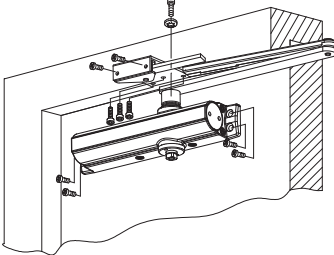

**3** Rotate the bottom pinion at approximately 90° with a wrench as illustrated and then assemble the main arm.

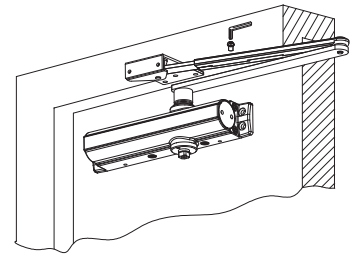

**4** Make sure the main arm is parallel to the door. Then attach the connecting arm.

## Closer Adjustments

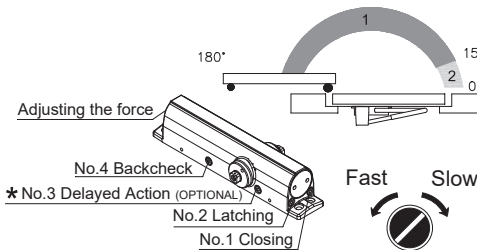

- ★ This product falls outside of its CE & Certifire approval when this feature is activated.
- After ensuring all fixings are tightened, operate the door closer to check its performance, making adjustments as necessary.

The following adjustment valves have a maximum adjustment of 1 full turn per valve.

**PLEASE NOTE** over adjustment will damage the mechanism and/or the performance of the door closer and invalidate its guarantee. Adjust Backcheck (valve #4) and the optional Delayed Action (valve #3) before adjusting the Closing Speed (valve #1) and Latching Action (valve #2).

### Fixing in Fig.66

Power size	Max. Door width	Max. Door weight	Max. Door opening	Number of turns
No.1	750mm	20Kg	180°	7CCW
2	850mm	40Kg	180°	4CCW
★ 3	950mm	60Kg	180°	0

★ Factory preset  
CW:Clockwise CCW:Counterclockwise

## Installation and Maintenance Instructions:

### Warning



1. Please note the minimum power size requirement for fire / smoke door assemblies is 3 as required by Approved Document B.
2. Do not install mechanical hold open devices on fire / smoke door assemblies.
3. Take care not to exceed the maximum opening angle as detailed above.
4. Care and attention must be taken when adjusting any of the units control valves to avoid damage through over adjustment.
5. All Synergy Door Closer units are sealed for life and the internal components assembled under high load, therefore, tampering with the mechanism is to be strictly avoided.

### After Installation



1. When the closer operates to close the door from its maximum opening position, it should ensure the lock latchbolt and any seals are overcome and the leaf returned into its frame.
2. When the door is slightly open and the latch bolt resting against the strike, release the door to ensure the leaf fully closes into its frame.

### Maintenance



1. Once the unit has been correctly fitted it is recommended that periodic checks (every six months) are carried out to ensure all fixings are tight and the door closes freely and positively into the frame, without slamming.
2. A light oil lubricant (non-graphite) should be applied to the moving joints and exposed pivot points.